

THIS DRAWING IS UNPUBLISHED. RELEASED FOR PUBLICATION
 © COPYRIGHT BY TYCO ELECTRONICS CORPORATION. ALL RIGHTS RESERVED.

| LOC | DIST | REVISIONS | | | | | |
|-----|------|-----------|-----|--------------------------|---------|-----|------|
| | | P | LTR | DESCRIPTION | DATE | DWN | APVD |
| G | 86 | | N | REDRAWN PER 0G3A-0400-04 | 02JUN04 | JR | MS |

- 1 TONGUE MATERIAL THICKNESS .040±.003
- △ 2 BODY: COPPER PER ASTM B-152
TIN PER ASTM B-545
INSULATION: PVC, COLOR - RED
METALLIC SLEEVE: COPPER PER ASTM B-152
METALLIC BAND: STEEL PER ASTM A109
- 3 FOR .298 MAX WIRE INSULATION DIA

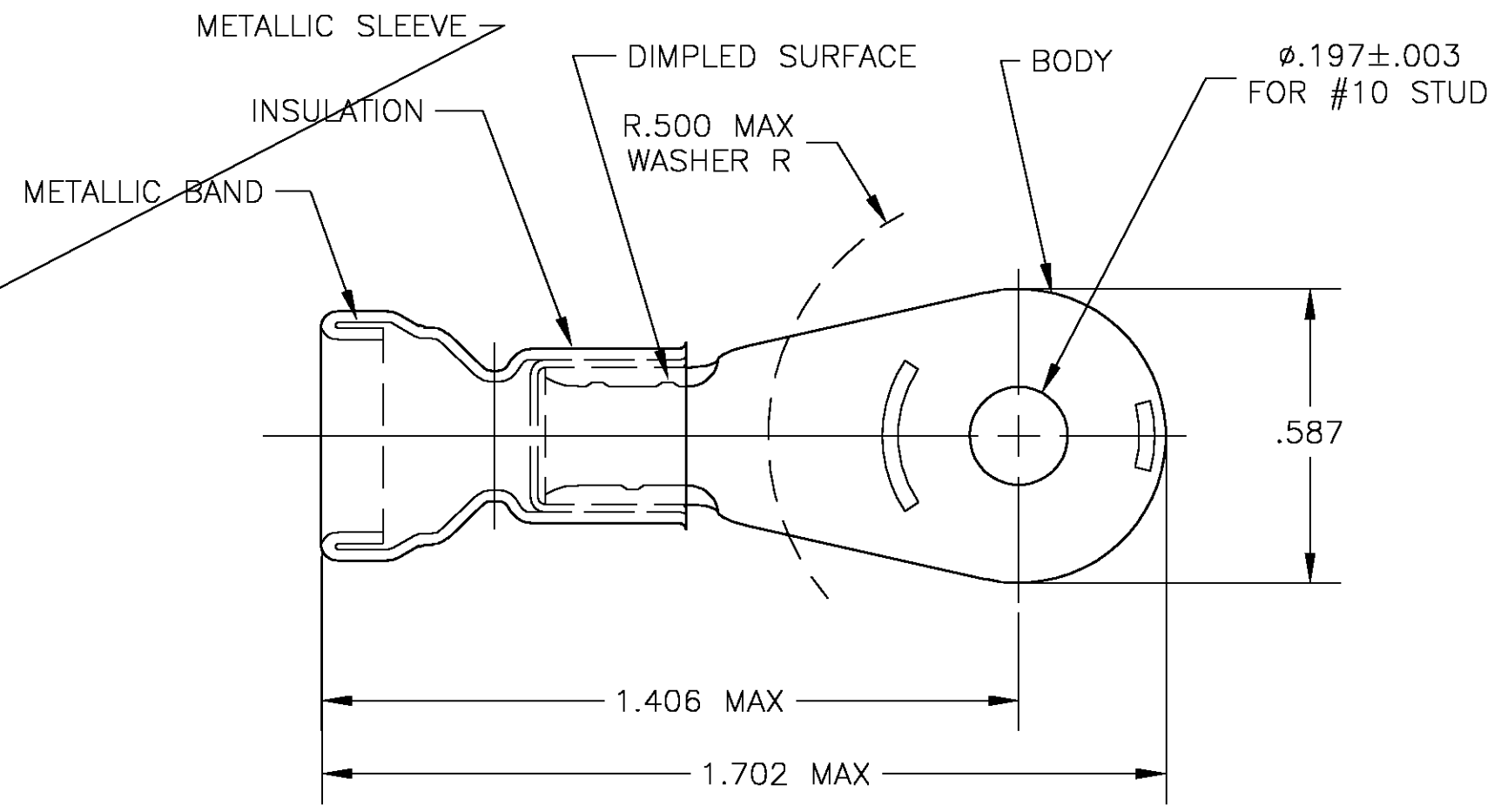

| QTY | DESCRIPTION | PART NO |
|-----|---------------|---------|
| 1 | WIRE TERMINAL | 322002 |

| | | | | |
|--|--|------------------------------|---|--------------|
| THIS DRAWING IS A CONTROLLED DOCUMENT. | | DWN jr_ruth 02JUN04 | Tyco Electronics Corporation Harrisburg, PA 17105 | |
| DIMENSIONS: INCHES | | CHK MJ SPICER 02JUN04 | | |
| | | APVD MJ SPICER 02JUN04 | NAME TERMINAL, AMPLI-BOND, RING TONGUE WIRE SIZE: 8 | |
| TOLERANCES UNLESS OTHERWISE SPECIFIED: | | PRODUCT SPEC | RESTRICTED TO | |
| 0 PLC ± - | | APPLICATION SPEC | SIZE | CAGE CODE |
| 1 PLC ± - | | WEIGHT | A3 | 00779 |
| 2 PLC ± - | | CUSTOMER DRAWING | DRAWING NO C-322002 | |
| 3 PLC ± .008 | | SCALE | 3:1 | SHEET 1 OF 1 |
| 4 PLC ± - | | REV | N | |
| ANGLES ± 5' | | | | |
| MATERIAL - △ 2 | | | | |
| FINISH - △ 2 | | | | |